



ISOLOK[®] SERIES MSE **Automatic Sampler**

***For High Viscosity Products
at Pressures 0-150 PSIG***



ISOLOK[®] SERIES MSE SAMPLER

Features

- Samples high viscosity materials using a contracting annulus that ejects each collected sample into the attached container
- Collects a fixed volume up to 10 cc of sample per cycle in process pressures from atmospheric to 150 psig (10.3 barg)
- Ideal for liquids or slurries up to 150,000 centipoise
- Unique co-axial pneumatic cylinders

Options

- Port closures
- Line adapters
- Several types of containers
- Sampler enclosures (with or without heater)
- Sample heating or refrigeration
- Optional materials of construction and seal choices

Description

The ISOLOK[®] MSE series of samplers enable the collection of accurate samples of high viscosity materials such as toothpaste, peanut butter, tomato paste, juice concentrates — even rocket propellant. The MSE delivers a fixed volume of sample with each cycle. All metal parts are type 316 stainless steel with a polished finish. The sampler mounts onto the process line using a 2" Tri-Clamp ferrule mount held with a clamp and gasket. All product-contact seals are FDA-recognized elastomer compounds selected to meet application conditions.

The MSE's dual air cylinders extend the plunger into the process, the annulus opens and draws in product. The plunger retracts, holding the sample in the annulus. Once fully retracted, the annulus collapses, ejecting the sample into the container. The operator is isolated from the process at all times by the sampler's seal design, and the sample captured in the container is locked out from external influences.

SAMPLING PROCESS

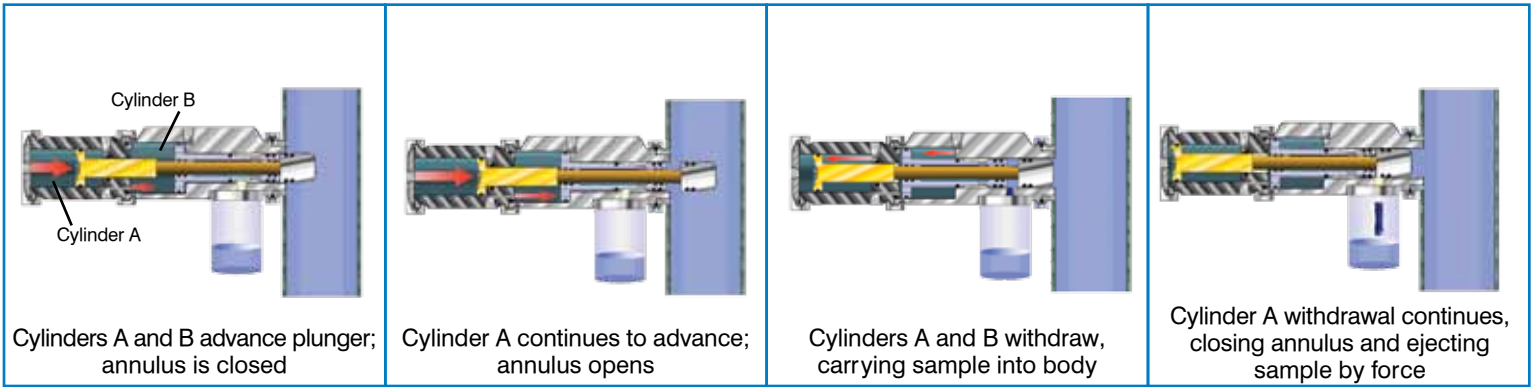

ISOLOK® MSE TECHNICAL DATA

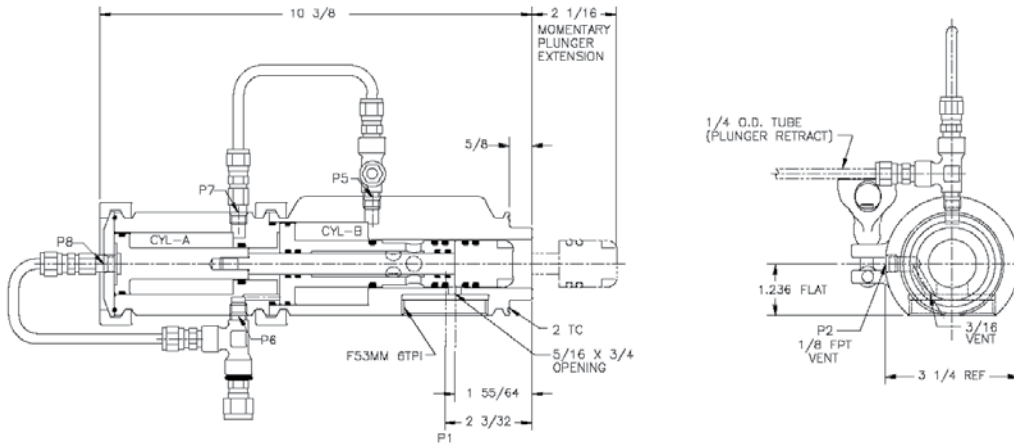

SPECIFICATIONS

Sample Volume per Cycle	max. 10 cc
Line Mounting Options	Tri-clamp or custom
Compressed Air Requirements	2 SCFM @ 90 psi (.05 m ³ /min @ 6.2 bar)
Materials of Construction	316 stainless steel
Actuator and Static Seals	TFE or Viton®
Plunger Seals	Buna-N, Viton® or custom
Overall Dimensions, length x diameter	10.3" x 4" (26 cm x 10 cm)
Net weight, not including controller or accessories	16.6 lb (7.5 kg)

Viton is a registered trademark of E. I. Du Pont de Nemours and Company.

⚠ WARNING

It is solely the responsibility of the end-user, through its own analysis and testing, to select products and materials suitable for their specific application requirements, ensure they are properly installed, safely applied, properly maintained, and limit their use to their intended purpose. Improper selection, installation, or use may result in personal injury or property damage.

CE European Authorized Rep:
OBELIS
Bd. General Wahis 53-1030
Brussels Belgium

Ex II 2GD TX



SENTRY EQUIPMENT CORP

966 Blue Ribbon Circle North
Oconomowoc, WI 53066 USA
Tel: 262-567-7256 • Fax: 262-567-4523

E-mail:
sales@sentry-equip.com

Website:
www.sentry-equip.com



For further information, contact: