

DBF By-Pass Feeders

By-Pass Feeders

Neptune By-Pass Feeders are a convenient method of introducing treatment chemicals into closed circulating water systems.

Neptune By-Pass Feeders are ideal for treating hot and chilled water circulating loops used in heating and air conditioning systems, process heating and cooling or large engine water jackets.

Neptune offers two styles of By-Pass Feeders: A vertical style with dish bottom in and a vertical style with dish bottom out.

Filters are available for system cleanup and monitoring.

A high pressure cap rated to 300 psi is now standard. The first closure improvement in over two decades.

Request Bulletin VTF-09 for VTF styles with flat bottom and no legs.

Neptune

A DOVER COMPANY

**BY-PASS FEEDERS
- VERTICAL STYLE**

**DISH BOTTOM OUT
MODEL DBF-5HP**



Caps



OLD STYLE CAPS

Three lug, 1/3 turn design rated to 200 psi.

NEPTUNE HIGH PRESSURE CAP

Coarse thread, 2 1/2 turn design rated to 300 psi.

All Neptune By-Pass Feeders offer the new style, quick opening, high pressure closure.

These closures offer better sealing with less force and eliminate the need for tools. Design binds cap tightly when under pressure making it necessary to bleed pressure from tank before removing cap.

Underside of cap which contacts liquid is epoxy-coated.

Vertical Style - Dish Bottom Out

The "DBF" series features wide-mouth caps manufactured by Neptune. These caps utilize a square section "O" ring seal and will **close easily by hand**. Advantages of this series are demountable leg extensions and a **full bottom drain**. Optional Filter Bag Kit may be added.

"DBFC" models include a built-in support and mounting for a cartridge filter (order cartridge separately).

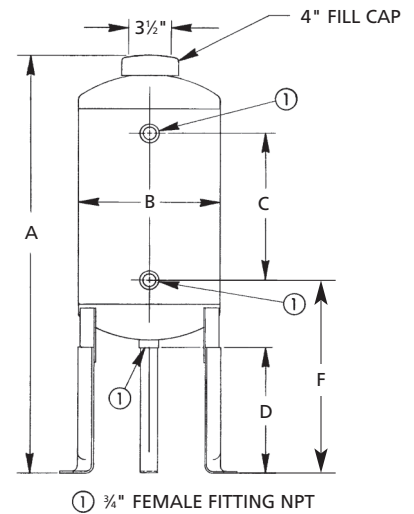
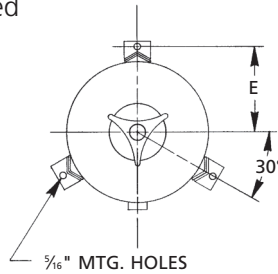

MODEL NUMBER	FILTER	APPROX. CAPACITY	MAX. PRESSURE*	A	B	C	D	E	F	SHIP WEIGHT
DBF-2HP	Optional†	2 Gallons	300 psi	3 1/4"	6"	12 3/4"	8 5/8"	4 1/8"	13 1/4"	23 lbs.
DBFC-2	Cartridge	2 Gallons	300 psi	3 1/4"	6"	12 3/4"	8 5/8"	4 1/8"	13 1/4"	23 lbs.
DBF-5HP	Optional†	5 Gallons	300 psi	2 9/4"	10"	10 1/2"	8"	6 1/8"	13"	38 lbs.
DBFC-5	Cartridge	5 Gallons	300 psi	2 9/4"	10"	10 1/2"	8"	6 1/8"	13"	38 lbs.
DBF-10HP	Optional†	10 Gallons	300 psi	4 5/4"	10"	26 1/2"	8"	6 1/8"	13"	61 lbs.

*At 200°F Max.

†Filter support not included with base unit. Purchase optional filter bag kit.

Cartridge Filter Units

"DBFC" models include a built-in support and mounting for a cartridge filter. (Order cartridge separately.)

Cartridge filter modification cannot be installed in DBF models; model DBFC must be ordered for use with cartridge filter.

DBFC-5 with cartridge filter installed

Filter Assembly

PART NO.	DESCRIPTION
107290	5 Micron Pleated Filter
107287	20 Micron Pleated Filter



Filter Bag Kits

Available for all "VTF" and "DBF" models up to 10 gallons. Kit includes bag, bag frame, tubing and connectors. The addition of a filter bag allows the By-Pass Feeder to function simultaneously as a side stream filter. (A clean bag is rated at approximately 30 microns.) Cannot be used with DBFC models.

Request Bulletin VTF-09 for VTF styles with flat bottom and no legs.

VTF-2HP with filter bag kit installed

(bag frame shown in front of bag for clarity only)

MODEL	FOR USE ON
FBK-2	VTF-2HP, DBF-2HP
FBK-5	VTF-5HP, DBF-5HP
FBK-10	VTF-10HP, DBF-10HP

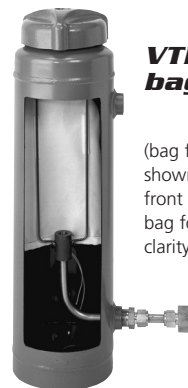

SOLD BY:

P.O. Box 247 • Lansdale, PA 19446-0247
 Tel: 215-699-8700 • Fax: 215-699-0370
 Toll-Free Tel: 1-888-3NEPTUNE (1-888-363-7886)
 Toll-Free Fax: 1-800-255-4017
 Web Site: <http://www.neptune1.com>
 E-mail: pump@neptune1.com

