



## Series MP7000

### Purpose

The Neptune Series MP7000 is a mechanically actuated diaphragm metering pump engineered from the ground up to be more robust and durable than similar mechanical diaphragm pump designs. The MP7000 pump incorporates the ruggedness of a hydraulic diaphragm metering pump, eliminates the need for intermediate fluid or hydraulic oil to actuate the diaphragm and eliminates the potential for gearbox oil to contaminate the process since it has an oil free gearbox design. The result is a pump design that provides reliable and accurate dosing of a wide range of mild to aggressive chemicals, including those used in industrial and municipal water and wastewater treatment, chemical processing and agriculture.

The MP7000's finned gearbox dissipates the heat created during normal operation more readily than other designs. The straight-through flow design of the MP7000 liquid end and the elimination of the contour plate result in improved flow characteristics, making the pump well-suited for pumping difficult chemicals such as viscous fluids, shear-sensitive fluids and fluids with suspended solids.

### Benefits

- Heavy-duty, corrosion-resistant aluminum gearbox
- Finned gearbox design dissipates heat more efficiently than other designs
- Rugged bronze gears are quiet-running and provide long service life
- Oversize check valves improve performance and minimize friction losses
- Short stroke length reduces diaphragm stress and promotes longer diaphragm life
- Superior performance when pumping chemicals such as sodium hypochlorite, which can off-gas
- Excellent suction lift for water-like chemicals

For higher pressures,  
request Bulletin DP-1100  
and Bulletin DP-2000.



CERTIFICATIONS & ASSOCIATIONS:



# Neptune Series MP7000

## Mechanically Actuated Diaphragm Metering Pumps

### Features

- Capacities to 27 gph (102 lph)
- Operating pressures to 235 psi (16 bar)
- 10:1 turndown via micrometer-type knob with high-contrast, easy-to-read scale
- Repeatable metering accuracy is  $\pm 2\%$  of full scale (at constant hydraulic conditions)
- Rugged, PTFE-faced, pre-formed composite diaphragm with steel backing plate assures volumetric accuracy throughout the capacity range
- Pump capacity can be easily adjusted while pump is running
- Self loading micrometer that prevents drift
- Optional automatic speed control with variable frequency or SCR drive
- All models include standard 63 IEC motor adapter

MODEL MP7010-CN5

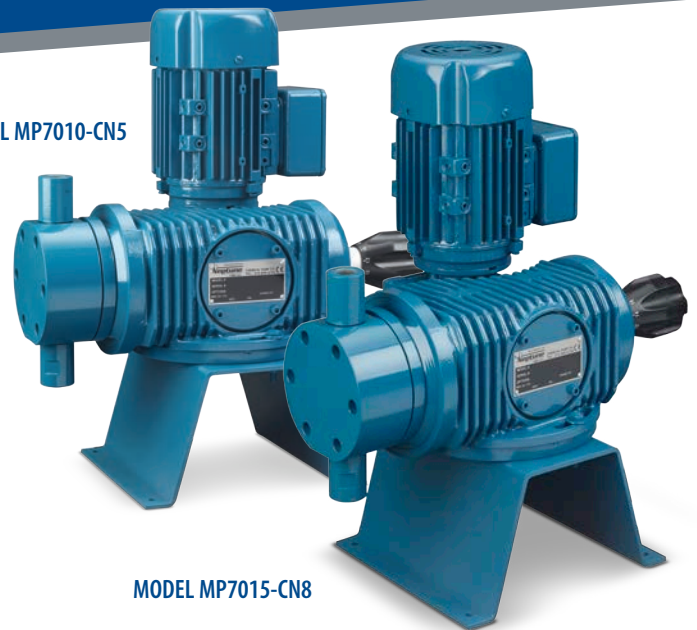

MODEL MP7015-CN8

### Selection Chart

Model	Liquid End	Capacity/Horsepower	Maximum Pressure	Stroke Speed	Stroke Length	Diaphragm Diameter	Shipping Weight (Lbs)
MP7007-AN3	316SS	2.3 GPH	235 PSI (16.2 BAR)	233	0.085 inch (2.2 mm)	1.44 inch (36.5 mm)	38
MP7007-AN5	PVC	(8.8 LPH)					38
MP7007-AN8	PVDF	1/4 HP					38
MP7015-BN3	316SS	4.8 GPH	200 PSI (13.8 BAR)	117	0.090 inch (2.3 mm)	1.9 inch (48 mm)	38
MP7015-BN5	PVC	(18.1 LPH)					38
MP7015-BN8	PVDF	1/4 HP					38
MP7010-BN3	316SS	6.9 GPH	200 PSI (13.8 BAR)	175	0.090 inch (2.3 mm)	1.9 inch (48 mm)	38
MP7010-BN5	PVC	(21.6 LPH)					38
MP7010-BN8	PVDF	1/4 HP					38
MP7007-BN3	316SS	9 GPH	200 PSI (13.8 BAR)	233	0.090 inch (2.3 mm)	1.9 inch (48 mm)	38
MP7007-BN5	PVC	(34.1 LPH)					38
MP7007-BN8	PVDF	1/4 HP					38
MP7015-CN3	316SS	9 GPH	150 PSI (10.4 BAR)	117	0.105 inch (2.7 mm)	2.8 inch (71 mm)	43
MP7015-CN5	PVC	(34.1 LPH)					43
MP7015-CN8	PVDF	1/4 HP					43
MP7010-CN3	316SS	13.5 GPH	150 PSI (10.4 BAR)	175	0.105 inch (2.7 mm)	2.8 inch (71 mm)	43
MP7010-CN5	PVC	(51.1 LPH)					43
MP7010-CN8	PVDF	1/4 HP					43
MP7007-CN3	316SS	18 GPH	150 PSI (10.4 BAR)	233	0.105 inch (2.7 mm)	2.8 inch (71 mm)	43
MP7007-CN5	PVC	(68.1 LPH)					43
MP7007-CN8	PVDF	1/4 HP					43
MP7015-DN3	316SS	27 GPH	80 PSI (5.5 BAR)	117	0.19 inch (4.8 mm)	3.9 inch (99 mm)	45
MP7015-DN5	PVC	(102.1 LPH)					45
MP7015-DN8	PVDF	1/4 HP					45

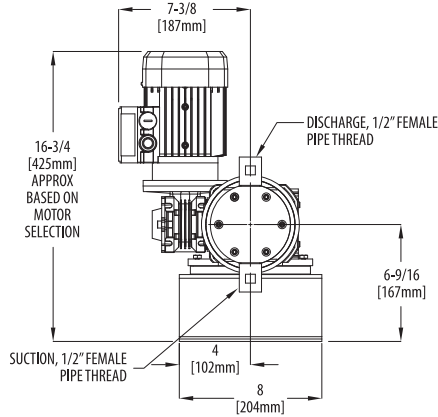
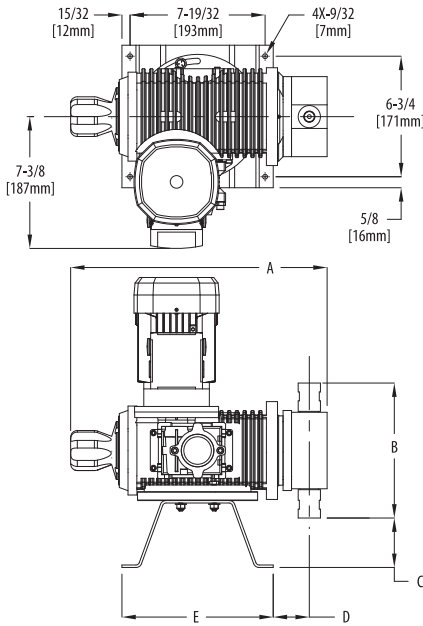

DIMENSIONS		
Item	Standard (inches)	Metric (mm)
<b>MP7007-AN</b>		
A	15	381
B	5-7/8	150
C	3-5/8	92
D	1-3/8	35
E	8-1/2	216
<b>MP7007-BN, MP7007-CN, MP7010-BN, MP7010-CN, MP7015-BN, MP7015-CN</b>		
A	16	406
B	7-1/2	191
C	2-13/16	71
D	2	51
E	8-1/2	216
<b>MP7105-DN</b>		
A	16-1/2	419
B	7-1/2	191
C	2-13/16	71
D	2-19/32	66
E	8-1/2	216
<b>MP7105-DN3</b>		
A	16	406
B	7-1/4	184
C	3	76
D	2-1/8	54
E	8-1/2	216

## Spare Parts Kit

The Series MP7000 Spare Parts Kit contains the liquid-end parts most susceptible to wear during a year of normal use. To keep the pump in good working order, Neptune recommends having a kit readily available.

Pump Head Size	Spare Part Kit #
MP7007-AN3	005357
MP7007-AN5	005358
MP7007-AN8	005359
MP7007-BN3	005360
MP7010-BN3	
MP7015-BN3	005361
MP7007-BN5	
MP7010-BN5	
MP7015-BN5	005362
MP7007-BN8	
MP7010-BN8	
MP7015-BN8	005363
MP7007-CN3	
MP7010-CN3	
MP7015-CN3	005364
MP7007-CN5	
MP7010-CN5	
MP7015-CN5	005365
MP7007-CN8	
MP7010-CN8	
MP7015-CN8	005366
MP7015-DN3	
MP7015-DN5	
MP7015-DN8	005368

## Application Information

### 1. External Relief Valve

An external relief valve is always required to protect the pump from the damage caused by over-pressurization of the discharge line during operation.

### 2. Pulsation Dampener

Use of a pulsation dampener is required if the discharge pipe is more than 10 ft. (3 m) long for the 70XX model and the discharge pressure is more than 25 psi (1.75 bar).

### 3. Recommended Pipe Diameter and Length

	Pump Models	
	MP70XX-ANX/MP70XX-BNX/MP70XX-CNXX	MP70XX-DNX
Suction Pipe Diameter	1/2" (12.7 mm)	3/4" (19.1 mm)
Maximum Lift	4' (1.2 m)	4' (1.2 m)
Discharge Pipe Diameter	3/8" (9.5 mm)	1/2" (12.7 mm)
Minimum Orifice At Injection Point	3/8" (9.5 mm)	1/2" (12.7 mm)

### 4. Use only Full Port Valves

in suction and discharge lines.

## Accessories and Options

### Relief Valves

An external relief valve is always required to protect the Series MP7000 pump from damage caused by over-pressurization of the discharge line during operation. Neptune offers adjustable relief valves in various sizes and materials of construction to meet any application requirement.

Available in PVC, PVDF, 316SS and Alloy 20 standard.

[Request Bulletin RV](#)

### Back Pressure Valves

An adjustable back pressure valve provides anti-syphon protection in pump installations where the suction pressure is higher than the discharge pressure. The spring-loaded valve generates a constant back pressure that also assures accurate metering when the Series MP7000 pump is injecting chemical into low discharge pressure. Neptune offers back pressure valves in various sizes and material of construction to meet any application requirement.

Available in PVC, PVDF, 316SS and Alloy 20 standard.

[Request Bulletin BP](#)

### Leak Detection

The Series MP7000 pump can be supplied with an optional diaphragm leak detector, which senses the early stages of diaphragm failure. The system consists of an electro-optic sensor mounted in the pump head behind the process diaphragm and a relay installed in a NEMA 4X enclosure. The leak detector can be wired to provide remote indication of diaphragm failure, shut down the pump and/or sound an alarm.

### Pulsation Dampeners

A pulsation dampener installed in the discharge of the Series MP7000 pump will smooth the pulsating flow typical of a reciprocating pump. A properly sized pulsation dampener can improve pump performance and reduce stress to the piping system and accessories. A pulsation dampener is required if the discharge pipe is more than 10 ft. (3 m) long and the discharge pressure is more than 25 psi (1.75 bar).

Available in PVC, polypropylene, 316SS and Alloy 20 bodies with Viton, EPDM or PTFE bladders.

[Request Bulletin PD](#)

### Materials of Construction

Material Code	Pump Head	Check Valve Body	Check Valve Ball	Valve O-Ring	Diaphragm
N3	316SS	316SS	316SS	None	PTFE
N5	PVC*	PVC*	Ceramic	Viton®	PTFE
N8	PVDF**	PVDF**	Ceramic	Viton	PTFE

\* PVC Heads are suitable for temperatures to 125°F (50°C)  
 \*\* PVDF Heads are suitable for temperatures to 200°F (93°C)  
 Valve O-ring is not used on the -DN3 pump heads  
 Viton® is a registered trademark of DuPont.

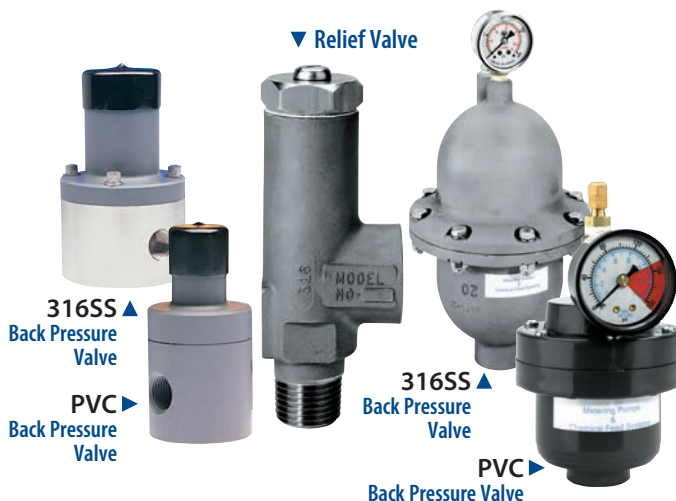

**Neptune™**

PSG  
 295 DeKalb Pike  
 North Wales, PA 19454 USA  
 P: +1 (215) 699-8700 • F: +1 (215) 699-0370  
[neptune1.com](http://neptune1.com)

**PSG**  
 a DOVER company

Distributed By: