

Pulsation Damper Plastic PVC Housing, Bladder Gas Bag, Low Pressure

GOTO : Pulsation Damper Plastic Poly-Prop. Housing Bladder Gas Bag LP

"PIPEGUARD Plas PVC" by PULSEGUARD  Since 1965

Typical "Pig Plas-PVC" Series Pulsation Damper, & options. PVC Plastic wetted parts + EP, Nitrile, Hypalon, Fluorel etc gas bags.

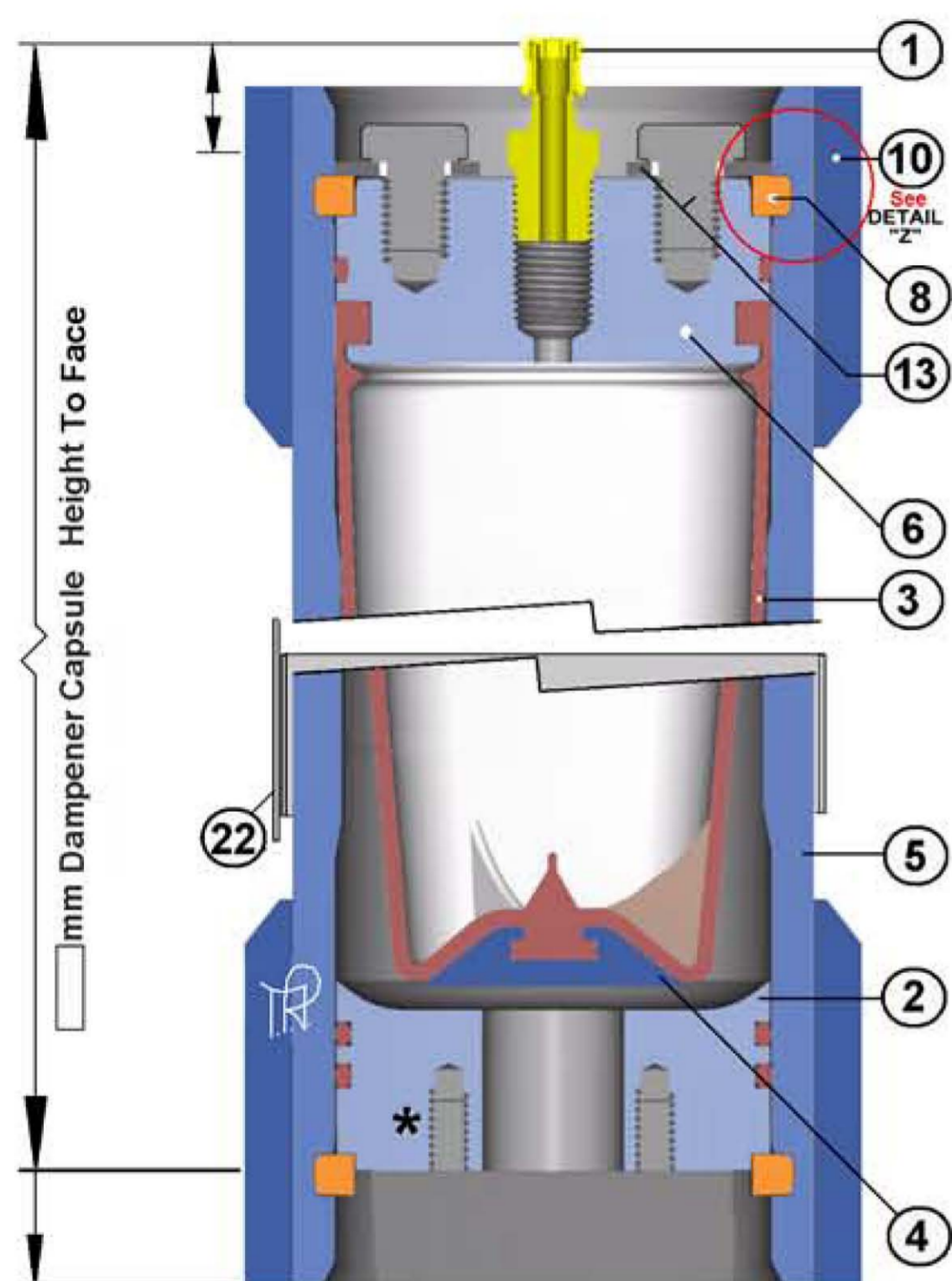

* Bolt holes have Helicoil Inserts

Available with 1 Male NPT No Flushability nor Pulse interception

mm addition to over all height to face for flush in place & pulsation intercept "Y-T" system pipe block.

Female threaded only available up to 3/4" pipe thread.

mm Damper Outside Diameter

A full Spares Kit Consists of : Pt Nbr. SK/B..... y..... *

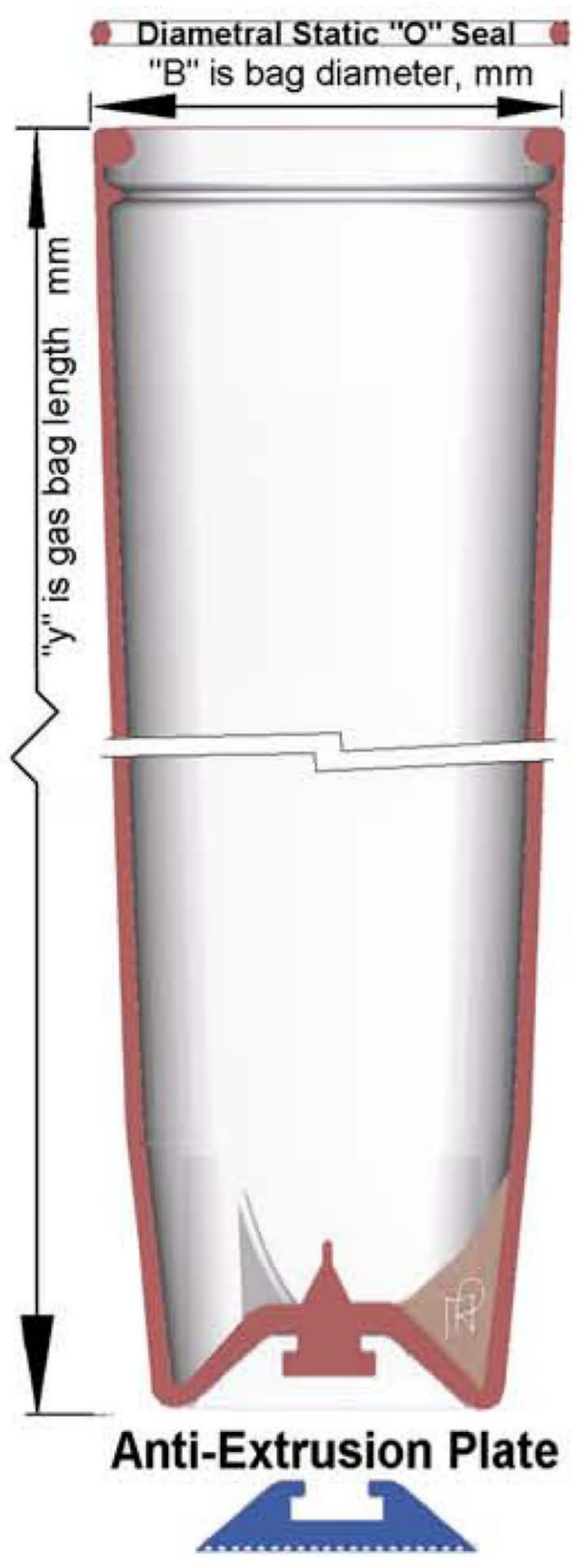

* Enter Letters Denoting Elastomer Typer Required
E = EPT/EPDM
N=Nitrile
H=Hypalon
B=Butyl
V=Fluoro Elastomer etc.

NOTE: "O" Ring cross sections
For units with Plastic Bodies Shore "A" IRH 50
3/32" Nom. 20mm ID to 26mm ID
1/8" Nom. 44mm ID to 65mm ID
1/4" .. 70mm ID to 220mm ID
3/8" .. 221mm ID to 310mm ID
Reserved for Jof-PLAS Sug-PLAS
1/2" .. mm ID to mm ID
Static Diametral Seal Grooves:
Groove depth 70% actual section
Groove width 1.5 x actual section
Face "O" Seals Shore "A" IRH 70
Up to 25mm flow hole 3/32" section
Over 25mm 1/8" (0.139" 3.5mm)

PED CONFORMITY DECLARATION as required by the PED ESSENTIAL SAFETY REQUIREMENTS "ESRs" state at 2 Design, under 2.1 the use of "SAFETY COEFFICIENTS". As Euro Norm 5500, and harmonised pressure vessel code 13445 do not have proven safety coefficients to apply, NO ONE complies with ESRs. Above statement applies to us also. Any documents of conformity issued particularly to ISO 9001-2000 holders by "Notified Bodies", must be a fraud. ALL Dampers are NON-CONFORMING

Exageration for Illustration of Fail Safe method.

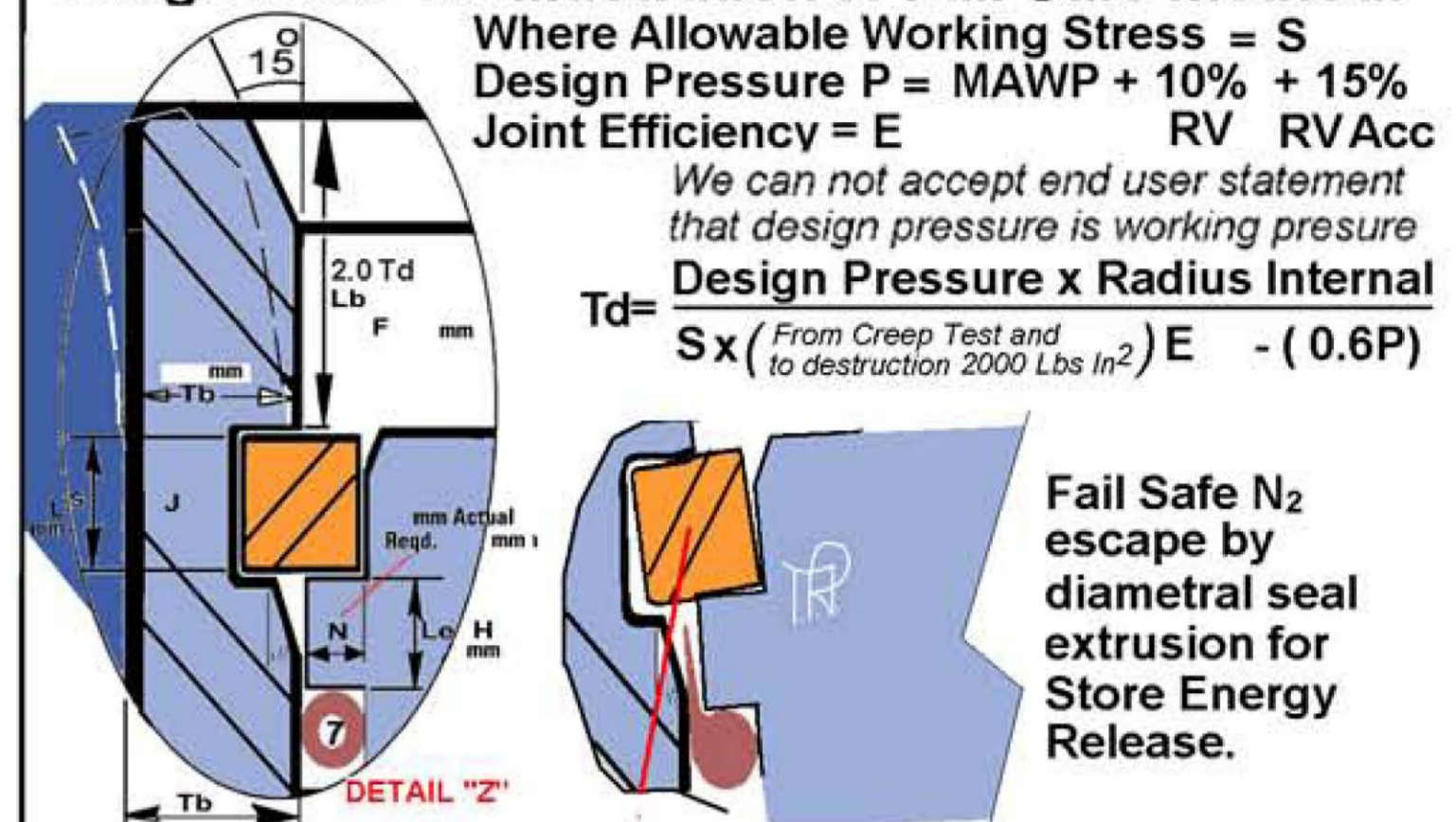

Item Nbr	Description / function	Internal "Heat/Cast No" PURCHASE No
22	Stainless Data Plate on stainless banding.	
14	"PB 45°x45°" machined from PVC Bar.	
13	Retaining Plate & Retaining bolts	
12	Face "O" seal with escape groove	
11	Socket Head Cap Screws, 4 Places. Diam. Lgth UH	
10	PVC Sleeve Glued, Pipe Mouth Re-inforcement	
9	Liquid End Plug PVC, Face sealing.	
8	Lock Ring, tamper-proof, 3 segments of circle.	
7	"head plug" - static diametral seal "O" ring	
6	End Closure / "head plug" - Gas End Plug	
5	Seamless Body PVC Pipe.	
4	Anti Extrusion Plate PVC	
3	Gas Bag "B--- y---" (mm Dia x mm high)	
2	Liquid End Plug PVC & helicoil thread inserts *	
1	Nitrogen Pre-Fill Valve	

Scale : Please do not print without "MAINTAIN ASPECT RATIO" on, Use A3 paper on A3 paper. Landscape 420mm wide
Part Nbr. / Drawing Ref : Date th 200- Rev Nbr
Pig - Plas PVC / _i_ _p/B_ _y_ /"O"/PVC + PB _"x_" FNPT-PVC

PulseGuard <http://www.PulseGuard.com>
PulseGuard für Deutschland <http://www.PulseGuard.co.uk>
PulseGuard, de langue Francaise www.pulsationdaempfer.com
PulseGuard, en Espanol / sud Amerique amortiguador-de-pulsaciones.com
PulseGuard, dlya Russkogovoryaschih pulsations-dampfer.com

PulseGuard is the USA registered trade mark of PulseGuard Inc.
PulseGuard is the UK registered trade mark of PulseGuard Ltd.
UK --44(0)161-480-9625 USA ---1910-270-2737

PulseGuard "Y-T" block, best flanging to system. In place of System "T", better flushing, & intercepts Pressure wave pulsation. Plain end, for glue only.

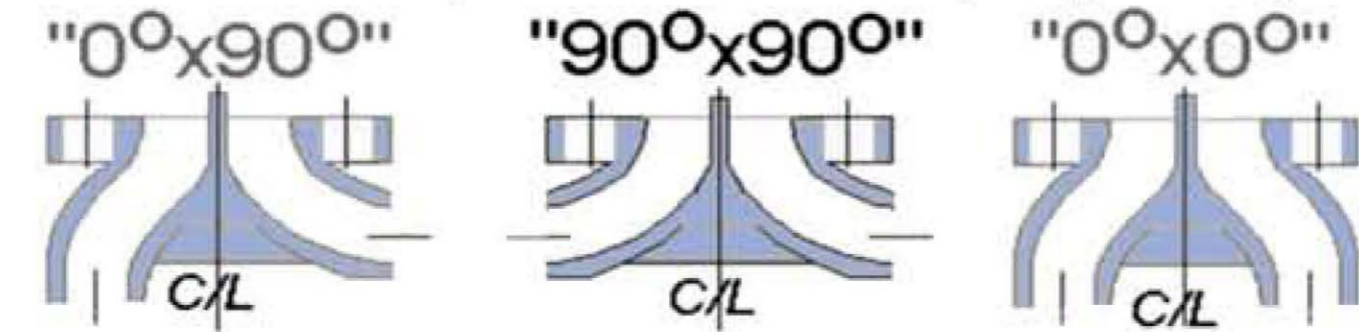

Called - Weld connection angles to this system fitting C/L

